

TM 11-5965-280-15

DEPARTMENT OF THE ARMY TECHNICAL MANUAL

OPERATOR, ORGANIZATIONAL
DS, GS, AND DEPOT MAINTENANCE MANUAL
INCLUDING REPAIR PARTS AND SPECIAL TOOLS LIST

HANDSET H-189/GR

This reprint includes all changes in effect at the time of
publication; changes 1 through 3.

HEADQUARTERS, DEPARTMENT OF THE ARMY

OCTOBER 1966

Change }
No. 1 }

HEADQUARTERS
DEPARTMENT OF THE ARMY
Washington, D. C., 13 April 1973

**Operator, Organizational, Direct Support, General
Support and Depot Maintenance Manual
Including Repair Parts and Special Tools List
HANDSET H-189/GR**

TM 11-5965-260-15, 20 October 1966, is changed as follows:

Page 9. Add below the heading of *9b*:

NOTE

Apply a small amount of waterproof silicone to each disassembled item before reassembling the handset.

Page 4. Add below the heading of *9d*:

NOTE

Apply a small amount of waterproof silicone to each disassembled item before reassembling the handset.

Page 6. Add below paragraph *10d*:

NOTE

Apply a small amount of waterproof silicone to each disassembled item before reassembling the handset.

Paragraph *10d(3)*. Add the following after the last sentence "(curved side down)."

Add the following below paragraph *10g*:

NOTE

Apply a small amount of waterproof silicone to each disassembled item before reassembling the handset.

By Order of the Secretary of the Army:

CREIGHTON W. ABRAMS
General, United States Army
Chief of Staff

Official:

VERNE L. BOWERS
Major General, United States Army
The Adjutant General

Distribution:

To be distributed in accordance with DA Form 12-51 (qty rqr block No. 325), Operator requirements for AN/PRC-25.

CHANGE }
NO. 2 }

HEADQUARTERS
DEPARTMENT OF THE ARMY
WASHINGTON, DC, 10 January 1979

**Operator, Organizational, Direct Support,
General Support,
And Depot Maintenance Manual
Including Repair Parts and Special Tools lists
HANDSET H-189/GR (NSN 5965-00-069-8886)**

TM 11-5965-280-15, 20 October 1966, is changed as follows:

The title is changed as shown above.

Page 1, paragraphs 2 and 3. Delete paragraphs 2 and 3 and substitute the following:

2. Indexes of Publications

a. *DA Pam 310-4*. Refer to the latest issue of DA Pam 310-4 to determine whether there are new editions, changes, or additional publications pertaining to the equipment.

b. *DA Pam 310-7*. Refer to DA Pam 310-7 to determine whether there are modification work orders (MWO'S) pertaining to the equipment.

3. Forms and Records

a. *Reports of Maintenance and Unsatisfactory Equipment*. Maintenance forms, records, and reports which are to be used by maintenance personnel at all maintenance levels are listed in and prescribed by TM 38-750.

b. *Report of Packaging and Handling Deficiencies*. Fill out and forward DD Form 6 (Packaging Improvement Report) as prescribed in AR 700-58/NAVSUPINST 4030.29/AFR 71-13/MCO P4030.29A, and DLAR 4145.8.

c. *Discrepancy in Shipment Report (DISREP) (SF 361)*. Fill out and forward Discrepancy in Shipment Report (DISREP) (SF 361) as prescribed in AR 55-38/NAVSUPINST 4610.33B/AFR 75-18/MCO P4610.19C, and DLAR 4500.15.

Page 2, paragraphs 4, 5, 6, and 7. Delete paragraphs 4, 5, 6, and 7 and substitute the following:

4. Destruction of Army Electronics Materiel

Destruction of Army electronics materiel to prevent enemy use shall be in accordance with TM 750-244-2.

5. Administrative Storage

Administrative storage of equipment constitutes storage in a dry safe place.

6. Reporting of Errors

The reporting of errors, omissions, and recommendations for improving this publication by the individual is encouraged. Reports should be submitted on DA Form 2028 (Recommended Changes to Publications and Blank Forms), and forwarded direct to Commander, US Army Communications and Electronics Materiel Readiness Command, ATTN: DRSEL-ME-MQ, Fort Monmouth, NJ 07703.

7. Reporting Equipment Improvement Recommendations (EIR)

EIR's will be prepared using Standard Form 368, Quality Deficiency Report. Instructions for preparing EIR's are provided in TM 38-760, The Army Maintenance Management System. EIR's should be mailed direct to Commander, US Army Communications and Electronics Materiel Readiness Command, ATTN: DRSEL-ME-MQ, Fort Monmouth, NJ 07703. A reply will be furnished direct to you.

7.1. Hand Receipt Technical Manual

A Hand Receipt Technical Manual, TM 11-5965-280-15-HR, is available. It contains preprinted DA Form 2062 (Hand Receipt/Annex No.) listing the H-189/GR. The Hand Receipt Manual is published to aid property accountability and is available through: Commander, US Army Adjutant General Publications Center, ATTN: AGDL-OD, 1655 Woodson Road, St. Louis, MO 63114 in accordance with procedures for requisitioning publications through The Adjutant General Publication channels. The Hand Receipt Technical Manual is entitled: Hand Receipt Manual Covering the End Item/Components of End Item (COEI) Basic Issue Items (BII), and Additional Authorization List (AAL) Related to: Handset H-189/GR (NSN 5965-00-069-8886).

7.2. Purpose and Use

The H-189/GR is a lightweight handset. It is used with portable and vehicular radio equipment. The earphone portion is thin enough to slip under Combat Helmet M1.

7.3. Technical Characteristics

Frequency response 300 to 3,500 cps.
Weight 1 lb, 3 oz.
Microphone impedance 150 ohms.
Microphone resistance approximately 3.3 ohms.
Earphone impedance 1,000 ohms.
Earphone resistance Approximately 23 ohms.

7.4. Description

(fig. 1)

The H-189/GR is a light, watertight, durable handset. It is 8 inches long, 1-9/16 inches wide, and tapers in thickness from 7/8 inches to 3/8 inches. The microphone and earphone elements are plug-in type (fig. 2). A push switch (5, fig. 3), which is included in the handset, is a double-pole, single-throw bar-activated type with normally open contacts. When the bar is depressed, the contacts close in sequence; the microphone circuit first, and then the control circuit. The H-189/GR has a 24-inch retrac-

tile cord which will extend to over 6 feet. The cord is terminated in a 5-pin connector type U-229/U. A clip on the back of the handset permits it to be attached to clothing.

7.5. Connecting and Using H-189/GR

(fig. 1)

a. Connecting. Insert Connector U-229/U into the proper receptacle on the equipment and slowly rotate the connector clockwise with a steady forward pressure. When the guide pins of the connector are in the proper grooves, the connector will move forward and seat itself. Twist the knurled portion of the connector to the right and pull sharply to set the connector.

b. Using. Hold the handset so that the earphone is against the ear and the microphone is approximately one-half inch from the lips. The earphone can be slipped under Combat Helmet M1. To talk, depress the switch bar; to listen, release the switch bar.

c. Disconnecting. To disconnect the H-189/GR from the equipment, slowly rotate Connector U-229/U counterclockwise with a steady forward pressure.

Page 8, appendix A. Replace appendix A with the following:

**APPENDIX A
REFERENCES**

Following is a list of references applicable and available to the user of Handset H-189/GR.

DA Pam 310-4	Index of Technical Manuals, Technical Bulletins, Supply Manuals (Types 7, 8, and 9), Supply Bulletins and Lubrication Orders.
DA Pam 310-7	US Army Index of Modification Work Orders.
TM 11-2062	Test Sets I-142, I-142-A, I-142-B and Telephone Test Set AN/PTM-6.
TM 11-6625-366-15	Multimeters TS-352/U, TS-352A/U, and TS-352B/U.
TM 38-750	The Army Maintenance Management System (TAMMS).
TM 750-244-2	Procedures for Destruction of Electronics Materiel to Prevent Enemy Use (Electronics Command).

By Order of the Secretary of the Army:

Official:

J. C. PENNINGTON
Brigadier General, United States Army
The Adjutant General

BERNARD W. ROGERS
General, United States Army
Chief of Staff

Distribution:

To be distributed in accordance with DA Form 12-51 operator TM literature requirements for AN/PRC-25, AN/PRC-77, AN/GRC-125, and AN/GRC-160.

CHANGE }
 No. 3 }

HEADQUARTERS
 DEPARTMENT OF THE ARMY
 WASHINGTON, DC, 21 September 1979

Operator's, Organizational, Direct Support, General Support, and Depot Maintenance
 Manual Including Repair Parts and Special Tools Lists

Handset H-189/GR
 (NSN 5965-00-069-8886)

TM 11-5965-280-15, 20 October 1966, is changed as follows:

Page 3. Paragraph 8 is superseded as follows:

8. Operator's Preventive Maintenance

Preventive maintenance is the systematic care, servicing, and inspection of equipment to prevent the occurrence of trouble, to reduce downtime, and to assure that the equipment is in serviceable condition. To assist in maintaining serviceability, the chart (para 8.2) indicates what to check, how to check, and what the normal conditions are. If the defect cannot be remedied, higher category maintenance or repair is required. Records and reports of these checks and services must be made in accordance with the requirements set forth in TM 38-750. The procedures given in paragraph 8.2 cover routine systematic care for proper upkeep and operation of the equipment.

Paragraphs 8.1 through 8.6 are added after paragraph 8.

8.1. Operator's Preventive Maintenance Checks and Services

To be sure that your handset is ready for your mission, you must perform your WEEKLY (W) Preventive Maintenance Checks and Services (PMCS). When you are doing any PMCS or routine checks, keep in mind the warnings and cautions.

CAUTION

When cleaning the receiver-transmitter cover (9, fig. 2) and the microphone mouthpiece (4, fig. 2), do not insert sharp tools into the holes.

NOTES

Routine checks like cleaning, dusting, washing, checking for frayed cable, stowing items not in use, covering unused receptacles and checking for loose screws are not listed as PMCS checks. They are things that you should do anytime you see they must be done.

If your equipment must be kept in continuous operation, check and service those items that can be checked and serviced without disturbing operation. Make the complete checks and services when the equipment can be shut down.

Use the ITEM NO. column in your PMCS table as a source of numbers for the TM Item No. column on DA Form 2404, (Equipment Inspection and Maintenance Worksheet) in recording results of PMCS.

Deficiencies that cannot be corrected must be reported to higher category maintenance personnel. Records and reports of preventive maintenance must be made in accordance with procedures given in TM 38--750.

8.2. Operator's Preventive Maintenance Checks and Services Chart

NOTES

Perform the following checks before operation and weekly if:

You are the assigned operator and have not operated the item since the last weekly, or

You are operating the item for the first time. Perform the checks in the order listed.

W—Weekly

Item No.	Interval		Procedures Check for and have repaired or adjusted as necessary	Equipment is not ready/ available if:
	w	Item to be inspected		
1	*	Connection	Connect the handset to the equipment with which it is being used (para 7.5a).	Handset cannot be properly connected.
2	*	Equipment operation	<p>a. Operate the handset (para 7.5b) and communicate with another station. The voice communication should be clear and uninterrupted.</p> <p>b. Observe that the mechanical action of the switch is free of binding.</p>	<p>a. Equipment fails to operate properly.</p> <p>b. Switch binds.</p>

8.3. Scope of Organizational Maintenance

The maintenance duties assigned to the organizational repair person are listed below, together with a reference to the paragraphs covering the specific maintenance function.

a. Organizational preventive maintenance checks and services (para 8.6).

b. Organizational maintenance repair (para 9).

8.4. Organizational Preventive Maintenance

Preventive maintenance is the systematic care, servicing, and inspection of equipment to prevent the occurrence of trouble, to reduce downtime, and to assure that the equipment is in serviceable condition. To assist in maintaining serviceability, the chart (para 8.6) indicates what to check, how to check, and what the normal conditions are. If the defect cannot be remedied, higher category maintenance or repair is required. Records and reports of these checks and services must be made in accordance with the requirements set forth in TM 38-750. The procedures given in paragraph 8.6 cover

routine systematic care and cleaning for proper upkeep and operation of the equipment.

8.5. Organizational Preventive Maintenance Checks and Services Periods

To be sure that your handset is ready for your mission, you must perform your Quarterly (Q) Preventive Maintenance Checks and Services (PMCS). When you are doing any PMCS or routine checks, keep in mind the warnings and cautions.

NOTES

Routine checks like cleaning, dusting, washing, checking for frayed cables, stowing items not in use, covering unused receptacles and checking for loose screws are not listed as PMCS checks. They are things that you must do anytime you see they must be done. Use the ITEM NO. column in your PMCS table as a source of number for TM Item No. column on DA Form 2404 (Equipment Inspection and Maintenance Worksheet) in recording results of PMCS. Deficiencies that cannot be corrected must be reported to higher category maintenance personnel.

8.6. Organizational Preventive Maintenance Checks and Service Chart

Q-Quarterly

Item No.	Interval	Item to be Inspected	Procedures
	Q		
1	*	Modifications	Check DA Pam 310-7 to determine whether new applicable MWO's have been published. All URGENT MWO's must be applied immediately. All NORMAL MWO's must be scheduled.

Paragraph 9. Add "repair" after the word "maintenance" in the heading and in line 1.

Page 4, paragraph 9e. In line 8, "DC-4" is changed to read "Part No. DC4(71984)." Line 9, "(FSN 5870-221-5903)" is changed to read "(NSN 6850-00-177-5904 for 2 ounces, or NSN 6850-00-664-6012 for 8 ounces)."

Page 5, paragraph 10a(1) (a). "Tool Kit, RadaRand Radio Repairman TK-87/U" is changed to read "Tool Kit, Electronic TK-105/G." Paragraph 10a(1) (b). "Multimeter TS-352/U" is changed to read "Multimeter AN/USM-223."

Page 6, paragraph 10b. In lines 2 and 3 "Telephone Test Set AN/PTM-6" is changed to read "Test Set, Telephone TS-716/U."

Page 8. APPENDIX A. Delete "TM 11-2062" and "TM 11-6625-366-15" and add:

TM 11-6625-596-12 Operator's and Organizational Maintenance Manual (Including Repair Parts and Special Tools Lists): Telephone Test Set TS-716/U.

TM 11-6625-654-14 Operator's Organizational, Direct Support and General Support Maintenance Manual (Including Repair Parts and Special Tools Lists): Multimeter AN/USM-223.

Page 11. APPENDIX C is superseded as follows :

APPENDIX C

MAINTENANCE LOCATION

Section I. INTRODUCTION

C-1. General

This appendix provides a summary of the main maintenance operations for Handset, H-189-GR. It authorizes categories of maintenance for specific maintenance functions on repairable items and components and the tools and equipment required to perform each function. This appendix may be used as an aid in planning maintenance operations,

C-2. Maintenance Function

Maintenance functions will be limited to and defined as follows:

a. Inspect. To determine the serviceability of an item by comparing its physical, mechanical, and/or electrical characteristics with established standards through examination.

b. Test. To verify serviceability and to detect incipient failure by measuring the mechanical or electrical characteristics of an item and comparing those characteristics with prescribed standards.

c. Service. Operations required periodically to keep an item in proper operating condition, i.e., to clean (decontaminate), to preserve, to drain, to paint, or to replenish fuel, lubricants, hydraulic fluids, or compressed air supplies.

d. Adjust. To maintain, within prescribed limits, by bringing into proper or exact position, or by setting the operating characteristics to the specified parameters.

e. Align. To adjust specified variable elements of an item to bring about optimum or desired performance.

f. Calibrate. To determine and cause corrections to be made or to be adjusted on instruments or test measuring and diagnostic equipments used in precision measurement. Consists of comparisons of two instruments, one of which is a certified standard of known accuracy, to detect and adjust any discrepancy in the accuracy of the instrument being compared.

g. Install. The act of emplacing, seating, or fixing into position an item, part, module (component or assembly) in a manner to allow the proper functioning of the equipment or system.

h. Replace. The act of substituting a serviceable like type part, subassembly, or module (component or assembly) for an unserviceable counterpart.

i. Repair. The application of maintenance services (inspect, test, service, adjust, align, calibrate, replace) or other maintenance actions (welding, grinding, riveting, straightening facing, remachining, or resurfacing) to restore serviceability to an item by correcting specific damage, fault, malfunction, or failure in a part, subassembly, module (component or assembly) end item, or system.

j. Overhaul. That maintenance effort (service/action) necessary to restore an item to a completely serviceable/operational condition as prescribed by maintenance standards (i.e., DMWR) in appropriate technical publications. Overhaul is normally the highest degree of maintenance performed by the Army. Overhaul does not normally return an item to like new condition.

k. Rebuild. Consists of those services/actions necessary for the restoration of unserviceable

equipment to a like new condition in accordance with original manufacturing standards. Rebuild is the highest degree of material maintenance applied to Army equipment. The rebuild operation includes the act of returning to zero those age measurements (hours, miles, etc.) considered in classifying Army equipments/components.

C-3. Column Entries

a. Column 1, Group Number. Column 1 lists group numbers, the purpose of which is to identify components, assemblies, subassemblies, and modules with the next higher assembly.

b. Column 2, Component/Assembly. Column 2 contains the noun names of components, assemblies, subassemblies, and modules for which maintenance is authorized.

c. Column 3, Maintenance Functions. Column 3 lists the functions to be performed on the item listed in column 2. When items are listed without maintenance functions, it is solely for purpose of having the group numbers in the MAC and RPSTL coincide.

d. Column 4, Maintenance Category. Column 4 specifies, by the listing of a "work time" figure in the appropriate subcolumn(s), the lowest level of maintenance authorized to perform the function listed in column 3. This figure represents the active time required to perform that maintenance function at the indicated category of maintenance. If the number or complexity of the tasks within the listed maintenance function vary at different maintenance categories, appropriate "work time" figures will be shown for each category. The number of task-hours specified by the "work time" figure represents the average time required to restore an item (assembly, subassembly, component, module, end item or system) to a serviceable condition under typical field operating conditions. This time includes preparation time, troubleshooting time, and quality assurance/quality control time in addition to the time required to perform the specific tasks identified for the maintenance functions authorized in the maintenance allocation chart. Subcolumns of column 4 are as follows :

C—Operator/Crew
O—Organizational
F—Direct Support
H—General Support
D—Depot

e. Column 5, Tools and Equipment. Column 5 specifies by code, those common tool sets (not individual tools) and special tools, test, and support equipment required to perform the designated function.

f. Column 6, Remarks. Column 6 contains an alphabetical code which leads to the remark in section IV, Remarks, which is pertinent to the item opposite the particular code.

C-4. Tool and Test Equipment Requirements (Sec III)

a. Tool or Test Equipment Reference Code. The numbers in this column coincide with the numbers used in the tools and equipment column of the MAC. The numbers indicate the applicable tool or test equipment for the maintenance functions,

b. Maintenance Category. The codes in this column indicate the maintenance category allocated the tool or test equipment.

c. Nomenclature. This column lists the noun name and nomenclature of the tools and test equipment required to perform the maintenance functions,

d. National/NATO Stock Number. This column lists the National/NATO stock number of the specific tool or test equipment.

e. Tool Number. This column lists the manufacturer's part number of the tool followed by the Federal Supply Code for manufacturers (5-digit) in parentheses.

C-5. Remarks (Sec IV)

a. Reference Code. This code refers to the appropriate item in section II, column 6.

b. Remarks. This column provides the required explanatory information necessary to clarify items appearing in section II

APPENDIX C

MAINTENANCE LOCATION

Section I. INTRODUCTION

C-1. General

This appendix provides a summary of the maintenance operations for Handset, H-189-GR. It authorizes categories of maintenance for specific maintenance functions on repairable items and components and the tools and equipment required to perform each function. This appendix may be used as an aid in planning maintenance operations.

C-2. Maintenance Function

Maintenance functions will be limited to and defined as follows:

a. Inspect. To determine the serviceability of an item by comparing its physical, mechanical, and/or electrical characteristics with established standards through examination.

b. Test. To verify serviceability and to detect incipient failure by measuring the mechanical or electrical characteristics of an item and comparing those characteristics with prescribed standards.

c. Service. Operations required periodically to keep an item in proper operating condition, i.e., to clean (decontaminate), to preserve, to drain, to paint, or to replenish fuel, lubricants, hydraulic fluids, or compressed air supplies.

d. Adjust. To maintain, within prescribed limits, by bringing into proper or exact position, or by setting the operating characteristics to the specified parameters.

e. Align. To adjust specified variable elements of an item to bring about optimum or desired performance.

f. Calibrate. To determine and cause corrections to be made or to be adjusted on instruments or test measuring and diagnostic equipments used in precision measurement. Consists of comparisons of two instruments, one of which is a certified standard of known accuracy, to detect and adjust any discrepancy in the accuracy of the instrument being compared.

g. Install. The act of emplacing, seating, or fixing into position an item, part, module (component or assembly) in a manner to allow the proper functioning of the equipment or system.

h. Replace. The act of substituting a serviceable like type part, subassembly, or module (component or assembly) for an unserviceable counterpart.

i. Repair. The application of maintenance services (inspect, test, service, adjust, align, calibrate, replace) or other maintenance actions (welding, grinding, riveting, straightening facing, remachining, or resurfacing) to restore serviceability to an item by correcting specific damage, fault, malfunction, or failure in a part, subassembly, module (component or assembly) end item, or system.

j. Overhaul. That maintenance effort (service/action) necessary to restore an item to a completely serviceable/operational condition as prescribed by maintenance standards (i.e., DMWR) in appropriate technical publications. Overhaul is normally the highest degree of maintenance performed by the Army. Overhaul does not normally return an item to like new condition.

k. Rebuild. Consists of those services/actions necessary for the restoration of unserviceable

equipment to a like new condition in accordance with original manufacturing standards. Rebuild is the highest degree of material maintenance applied to Army equipment. The rebuild operation includes the act of returning to zero those age measurements (hours, miles, etc.) considered in classifying Army equipments/components.

C-3. Column Entries

a. Column 1, Group Number. Column 1 lists group numbers, the purpose of which is to identify components, assemblies, subassemblies, and modules with the next higher assembly.

b. Column 2, Component/Assembly. Column 2 contains the noun names of components, assemblies, subassemblies, and modules for which maintenance is authorized.

c. Column 3, Maintenance Functions. Column 3 lists the functions to be performed on the item listed in column 2. When items are listed without maintenance functions, it is solely for purpose of having the group numbers in the MAC and RPSTL coincide.

d. Column 4, Maintenance Category. Column 4 specifies, by the listing of a "work time" figure in the appropriate subcolumn(s), the lowest level of maintenance authorized to perform the function listed in column 3. This figure represents the active time required to perform that maintenance function at the indicated category of maintenance. If the number or complexity of the tasks within the listed maintenance function vary at different maintenance categories, appropriate "work time" figures will be shown for each category. The number of task-hours specified by the "work time" figure represents the average time required to restore an item (assembly, subassembly, component, module, end item or system) to a serviceable condition under typical field operating conditions. This time includes preparation time, troubleshooting time, and quality assurance/quality control time in addition to the time required to perform the specific tasks identified for the maintenance functions authorized in the maintenance allocation chart. Subcolumns of column 4 are as follows :

C—Operator/Crew
O—Organizational
F—Direct Support
H—General Support
D—Depot

e. Column 5, Tools and Equipment. Column 5 specifies by code, those common tool sets (not individual tools) and special tools, test, and support equipment required to perform the designated function.

f. Column 6, Remarks. Column 6 contains an alphabetical code which leads to the remark in section IV, Remarks, which is pertinent to the item opposite the particular code.

C-4. Tool and Test Equipment Requirements (Sec III)

a. Tool or Test Equipment Reference Code. The numbers in this column coincide with the numbers used in the tools and equipment column of the MAC. The numbers indicate the applicable tool or test equipment for the maintenance functions.

b. Maintenance Category. The codes in this column indicate the maintenance category allocated the tool or test equipment.

c. Nomenclature. This column lists the noun name and nomenclature of the tools and test equipment required to perform the maintenance functions.

d. National/NATO Stock Number. This column lists the National/NATO stock number of the specific tool or test equipment.

e. Tool Number. This column lists the manufacturer's part number of the tool followed by the Federal Supply Code for manufacturers (5-digit) in parentheses.

C-5. Remarks (Sec IV)

a. Reference Code. This code refers to the appropriate item in section II, column 6.

b. Remarks. This column provides the required explanatory information necessary to clarify items appearing in section II

SECTION II MAINTENANCE ALLOCATION CHART
FOR
HANDSET H-189/GR

(1) GROUP NUMBER	(2) COMPONENT ASSEMBLY	(3) MAINTENANCE FUNCTION	(4) MAINTENANCE CATEGORY					(5) TOOLS AND EQPT.	(6) REMARKS
			C	O	F	H	D		
00	HANDSET H-189/GR	Inspect Repair Repair Test	0.1	0.3	0.5 0.5			1 2 3,4	A B

SECTION III TOOL AND TEST EQUIPMENT REQUIREMENTS
FOR
HANDSET H-189/GR

TOOL OR TEST EQUIPMENT REF CODE	MAINTENANCE CATEGORY	NOMENCLATURE	NATIONAL/NATO STOCK NUMBER	TOOL NUMBER
1	D	TOOL KIT, ELECTRONIC EQUIPMENT TK-101/G	5180-00-064-5178	
2	F	TOOL KIT, ELECTRONIC EQUIPMENT TK-105/G	5180-00-610-8177	
3	F	MULTIMETER AM/USM-223	6625-00-999-7465	
4	F	TEST SET, TELEPHONE TS-716/U	6625-00-965-1433	

SECTION IV. REMARKS

REFERENCE CODE	REMARKS
A	BY REPLACING EARPHONE AND MICROPHONE ELEMENTS, GASKETS, AND MOISTURE SHIELDS.
B	ITEM NOT TO BE MAINTAINED ABOVE DIRECT SUPPORT ORGANIZATIONS.

By Order of the Secretary of the Army:

E. C. MEYER
General, United States Army
Chief of Staff

Official:

J. C. PENNINGTON
Major General, United States Army
The Adjutant General

Distribution:

To be distributed in accordance with DA Form 12-51, operator maintenance requirements for AN/PRC-25, AN/PRC 77, AN/GRC-125 and AV/GRC-160.

TECHNICAL MANUAL

No. 11-5965-280-15

HEADQUARTERS
DEPARTMENT OF THE ARMY
WASHINGTON, D. C., 20 October 1966

**OPERATOR, ORGANIZATIONAL, DS, GS, AND DEPOT MAINTENANCE MANUAL
INCLUDING REPAIR PARTS AND SPECIAL TOOLS LIST**

HANDSET H-189/GR

	Paragraph	Page
Scope	1	1
Index of equipment publications	2	1
Forms and records	3	1
Purpose and use	4	2
Technical characteristics	5	2
Description	6	2
Connecting and using H-189/GR	7	2
Operator's maintenance	8	3
Organizational maintenance	9	3
Direct support maintenance	10	5
APPENDIX A. REFERENCES		
B. BASIC ISSUE ITEMS		
C. MAINTENANCE ALLOCATION		
D. ORGANIZATIONAL , DS, GS, AND DEPOT REPAIR PARTS		

1. Scope

This manual describes Handset H-189/GR (fig. 1). It includes maintenance allocation (app C), maintenance instructions, and a list of repair parts available to organizational, direct support, general support, and depot personnel (app D).

2. Index of Equipment Publications

Refer to the latest issue of DA PAM 310-4 to determine whether there are new editions, changes, or additional publications pertaining to this equipment. Department of the

Army Pamphlet 310-4 is an index of current technical manuals, technical bulletins, supply manuals, supply bulletins, lubrication orders, and modification work orders available through publications supply channels. The index lists the individual parts (-15, -25P, etc) and the latest changes to and revisions of each equipment publication.

3. Forms and Records

a. *Reports of Maintenance and Unsatisfactory Equipment.* Use equipment forms and records in accordance with instructions in TM 38-750.

b. *Report of Damaged or Improper Shipment.* Fill out and forward DD Form 6 (Report of Damaged or Improper Shipment) as prescribed in AR 700-58 (Army), NAVSANDA publication 378 (Navy), and AFR 71-4 (Air Force).

c. *Reporting of Equipment Manual Improvements.* DA Form 2028 (Recommended Changes to DA Publications) will be used for reporting discrepancies and recommendations for improving this manual. The form will be completed by the individual using the manual and forwarded direct to Commanding General, U.S. Army Electronics Command, ATTN: AMSEL-MR-NMP-AD, Fort Monmouth, N. J., 07703.

4. Purpose and Use

The H-189/GR is a lightweight handset. It is used with portable and vehicular radio equipment. The earphone portion is thin enough to slip under Combat Helmet M1.

5. Technical Characteristics

- Frequency response . _____ 300 to 3,500 cps.
- Weight 1lb, 3 oz.
- Microphone impedance ._. 150 ohms.
- Microphone resistance _____ Approximately 3.3 ohms.
- Earphone impedance ----- 1,000 ohms.
- Earphone resistance ___ -_ Approximately 23 ohms.

6. Description

(fig. 1)

The H-189/GR is a light, watertight, durable handset. It is 8 inches long, 1-9/16

inches wide, and tapers in thickness from 7/8 inches to 3/8 inches. The microphone and earphone elements are plug-in type (fig. 2). A push switch (5, fig. 3), which is inclosed in the handset, is a double-pole, single-throw bar-activated type with normally open contacts. When the bar is depressed, the contacts close in sequence; the microphone circuit first, and then the control circuit. The H-189/GR has a 24-inch retractile cord which will extend to over 6 feet. The cord is terminated in a 5-pin connector type U-229/U. A clip on the back of the handset permits it to be attached to clothing.

7. Connecting and Using H-189/GR

(fig. 1)

a. *Connecting.* Insert Connector U-229/U into the proper receptacle on the equipment and slowly rotate the connector clockwise with a steady forward pressure. When the guide pins of the connector are in the proper grooves, the connector will move forward and seat itself. Twist the knurled portion of the connector to the right and pull sharply to set the connector.

b. *Using.* Hold the handset so that the earphone is against the ear and the microphone is approximately one-half inch from the lips. The earphone can be slipped under Combat Helmet M1. To talk, depress the switch bar; to listen, release the switch bar.

c. *Disconnecting.* To disconnect the H-189/GR from the equipment, slowly rotate Connector U-229/U counterclockwise with a steady forward pressure.

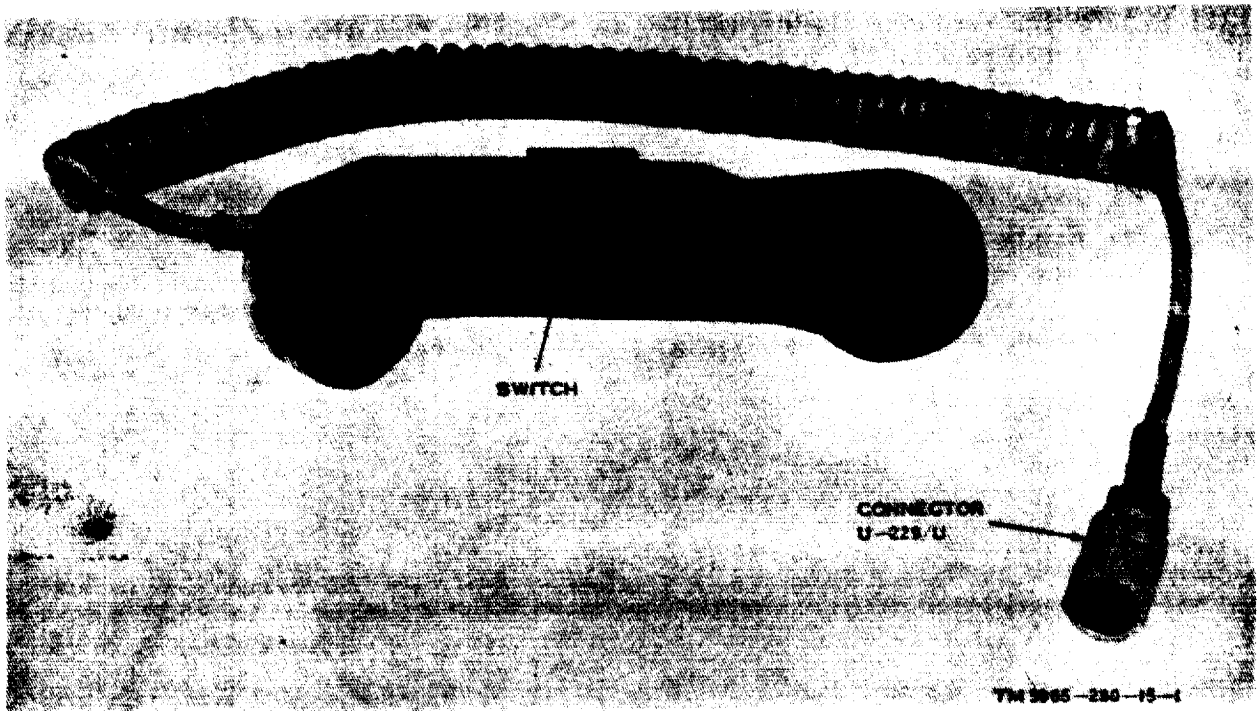

Figure 1. Handset H-189/GR.

8. Operator's Maintenance

Operator's maintenance consists primarily of preventive maintenance. Follow the preventive maintenance procedures for the equipment with which the H-189/GR is used.

Caution: When cleaning the receiver-transmitter cover (9, fig. 2) and the microphone mouthpiece (4, fig. 2), do not insert sharp tools into the holes.

9. Organizational Maintenance

(fig. 2)

Organizational maintenance consists of replacing the microphone and earphone elements, shields, packing, O-ring, and covers and lubrication of the O-ring in the U-229/U. The microphone and earphone elements can be checked by substitution. No tools are required for replacing these parts.

a. Removal of Microphone Element.

- (1) Remove the microphone mouthpiece (4) by turning it counterclockwise.
- (2) Remove the microphone shield (3),

the preformed packing (2), and the microphone element (1) from the handle.

b. Replacing Microphone Element.

- (1) Place the microphone element (1) in the handle with the element pins aligned with the contacts in the handle.

Caution: Failure to properly align the pins with the contacts may damage the element.

- (2) Replace the preformed packing (2) over the microphone element.
- (3) Replace the microphone shield (3) over the preformed packing.
- (4) Replace the microphone mouthpiece (4) and tighten it by turning it clockwise.

c. Removal of Earphone Element.

- (1) Remove the receiver-transmitter cover (9) by turning it counterclockwise.

- (2) Remove the earphone shield (8), the preformed packing (7), and the earphone element (6) from the handle.

d. Replacing Earphone Element.

- (1) Place the earphone element (6) in the handle with the pins aligned with the contacts in the handle.

Caution: Failure to properly align

the pins with the contacts may damage the element.

- (2) Replace the preformed packing (7) over the earphone element (6).
- (3) Replace the earphone shield (8) over the preformed packing.
- (4) Replace the receiver-transmitter cover (9) and tighten it by turning it clockwise.

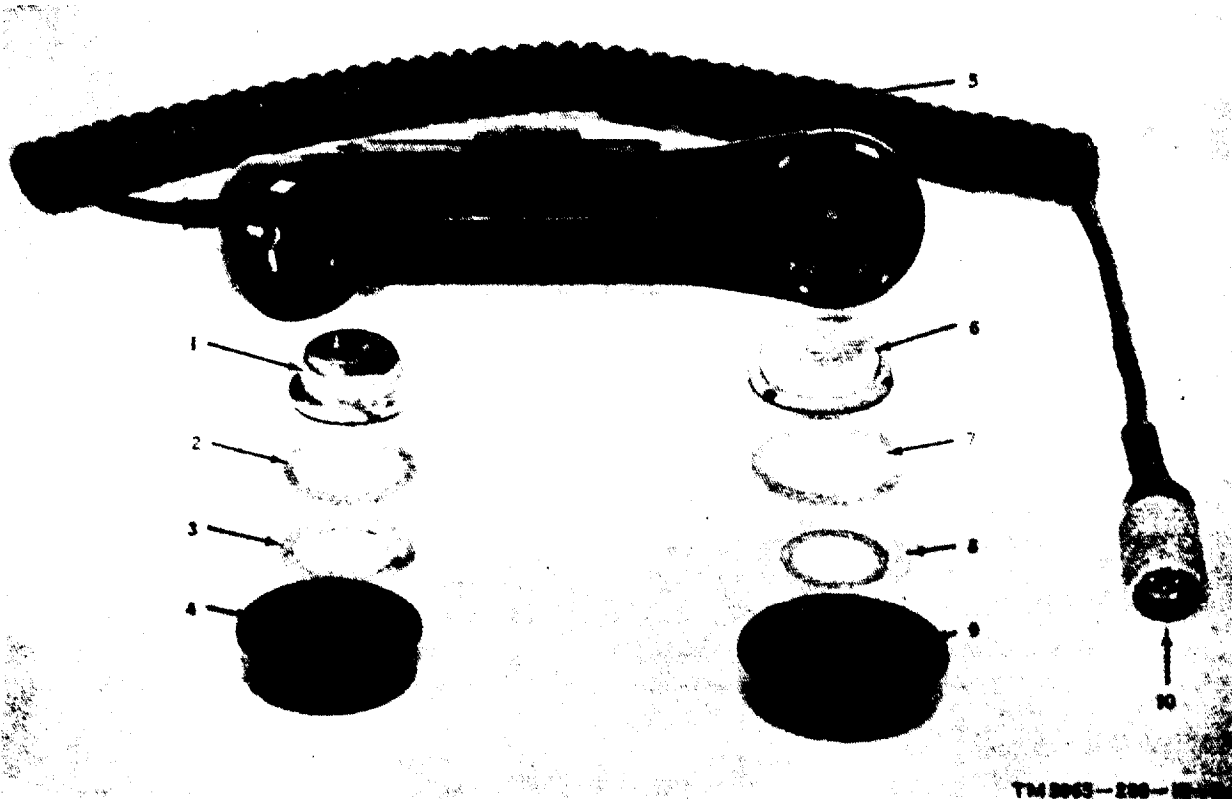

- 1 Microphone element (MK1)
- 2 Preformed packing (MP7)
- 3 Microphone shield (E2)
- 4 Microphone mouthpiece (MP6)
- 5 Cable assembly (W1)

- 6 Earphone element (HT1)
- 7 Preformed packing (MP8)
- 8 Earphone shield (E1)
- 9 Receiver-transmitter cover (MP4)
- 10 O-ring (MP2)

Figure 2. Handset H-189/GR, microphone and earphone elements removed.

e. Lubrication of O-ring in Connector U-229/U. The O-ring (10, fig. 2) fits in a groove inside the body of the U-229/U. It provides a seal when the H-189/GR is connected to a radio set. The O-ring may become lost or damaged when it is being connected or disconnected. To prevent this, apply a small amount of Dow-Corning Co. DC-4 Silicone

Compound (FSN 5870-221-5903) to the O-ring to permit it to roll in its groove. Apply it as often as necessary to obtain smooth connect and disconnect of the U-229/U.

Caution: DO NOT allow any of the lubricant to be applied to the contacts.

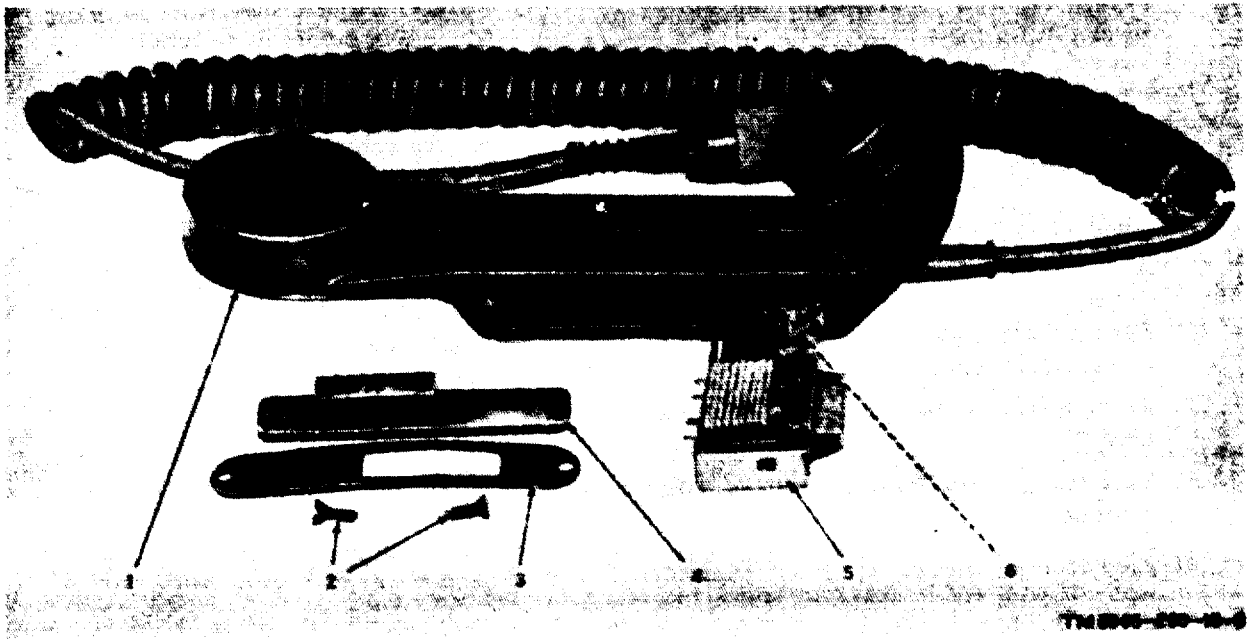

- | | |
|---|---|
| 1 Handle (MP5) | 4 Dust boot (MP1) |
| 2 Screw, machine; flathead, slotted, #6-32, 7/16 in. long, steel, black finish (H1) | 5 Switch (S1) |
| 3 Switch cover (MP3) | 6 Screw, machine; roundhead, slotted, #6-32, 3/8 in. long, stainless steel (H2) |

Figure 3. Handset H-189/GR, switch removed.

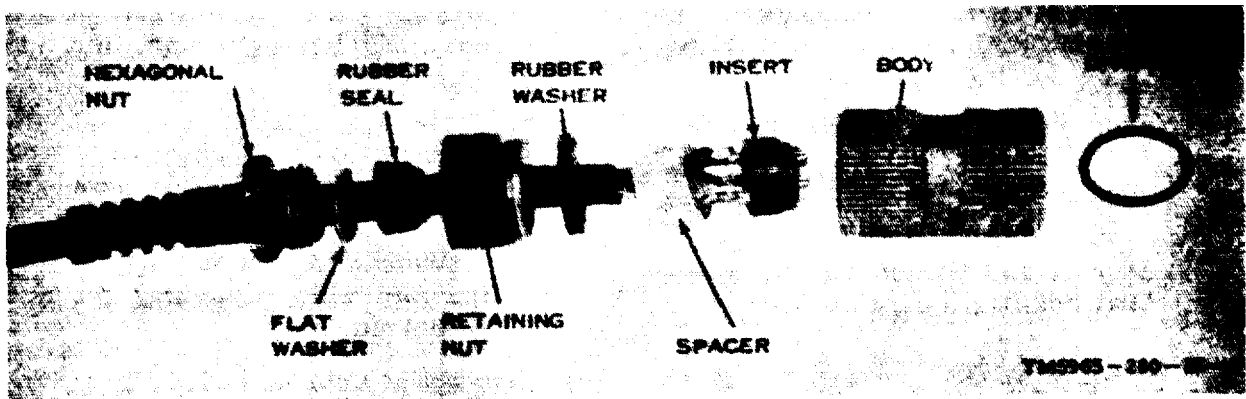

Figure 4. Connector U-229/U, exploded view.

10. Direct Support Maintenance

Direct support maintenance of the H-189/GR consists primarily of troubleshooting and replacing the switch, cord assembly, handle, and Connector U-229/U.

a. Troubleshooting.

(1) Tools and Test Equipment Required.

- (a) Tool Kit, Radar and Radio Repairman TK-87/U.
 - (b) Multimeter TS-352/U.
- (2) *Procedure.* The cord assembly, switch, and circuits in the handle may be checked by continuity measurements made with the TS-352/U.

Refer to the schematic diagram shown in figure 5.

b. Performance Test. The performance of the H-189/GR may be tested with Telephone Test Set AN/PTM-6.

c. Removal of Switch (fig. 3). To remove the switch from the handle, proceed as follows:

- (1) Remove the two screws that hold the switch cover.
- (2) Remove the switch cover and dust boot.
- (3) Pull the switch straight out of the handle.
- (4) With a pair of long-nosed pliers, slip each of the five leads from the arms of the switch contacts.

d. Replacement of Switch (fig. 3). To replace the switch in the handle, proceed as follows:

- (1) With a pair of long-nosed pliers, slip each of the five lead contacts on the arms of the switch contacts. Be sure that the leads are connected to the proper switch contacts. Refer to figure 5 for the color code.
- (2) Carefully push the switch into place in the handle.
- (3) Replace the dust boot and switch cover.
- (4) Replace and tighten the two screws that hold the switch cover.

e. Removal of Connector U-229/U (fig. 4). To remove the U-229/U from the cord, proceed as follows:

- (1) With a wrench, unscrew the hexagonal nut.

Caution: Be careful not to twist the cord while loosening the hexagonal nut.

- (2) Slip the hexagonal nut and flat washer back on the cord.
- (3) Hold the body and unscrew the retaining nut with a wrench.

(4) Push the insert out of the body with the eraser end of a pencil.

(5) Pull each of the contacts at the ends of the leads of the cord from the insert to remove the cord.

f. Replacement of Connector U-229/U (fig. 4). To replace the U-229/U on the cord, proceed as follows:

- (1) Assemble the parts of the U-229/U on the end of the cord as shown in figure 4. Make sure that the spacer has its slit toward the insert. Slip the fabric cord in the slit of the spacer with the knot outside the spacer.
- (2) Push each lead contact into the proper insert connector. Refer to figure 5 for the color code.
- (3) Place the threaded end of the body toward the insert. Align the index of the insert with the grooves in the body and push the insert into place in the body.
- (4) Bring the rubber washer and retaining nut into place. Hold the body and screw the retaining nut into the body. Tighten the retaining nut with a wrench.
- (5) Shove the rubber seal and flat washer into the retaining nut. Hold the body and screw the hexagonal nut firmly into the retaining nut.

Caution: Be careful not to twist the cord while tightening the hexagonal nut.

g. Removal of Cord Assembly. To remove cord assembly from the handle, proceed as follows :

Note. The cord assembly includes a U-229/U.

- (1) Remove the switch as explained in *c* above.
- (2) Remove the screw in the handle (6, fig. 3) that retains the lug which holds the cord assembly in the handle.
- (3) Slip the cord assembly out of the handle.

h. Replacement of Cord Assembly. To replace the cord assembly, proceed as follows:

- (1) Slip the end of the cord assembly through the hole in the handle and seat the cord firmly in place with the lug of the cord assembly in position to be held by the screw that was removed (*g(2)* above).
- (2) Replace and tighten the screw that was removed (*g(2)* above).
- (3) Replace the switch as explained in *d* above.

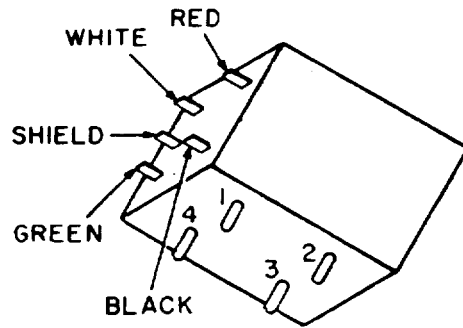
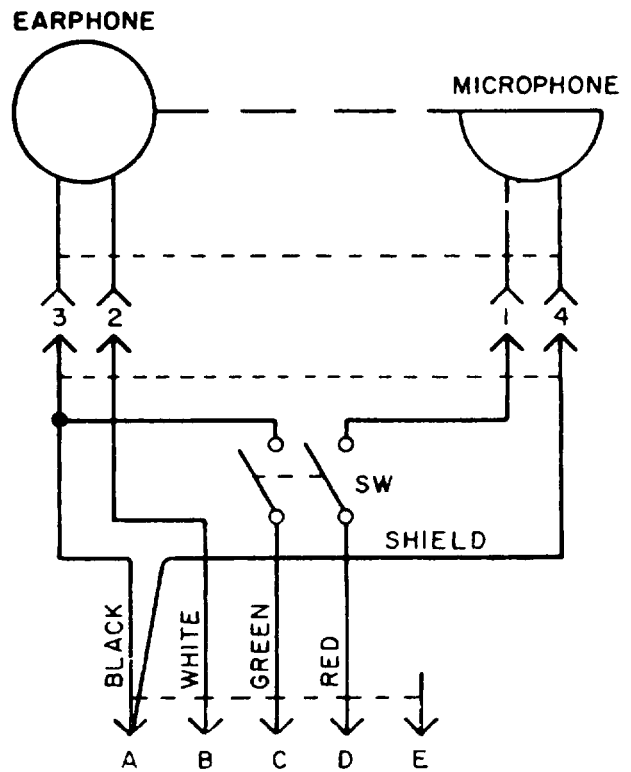

NOTE:
 BOTTOM AND END VIEW OF SWITCH
 TM5965-280-15-5

Figure 5. Handset H-189/GR, schematic diagram.

APPENDIX A

REFERENCES

Following is a list of references applicable and available to the user of Handset H-189/GR.

DA Pam 310-4 Index of Technical Manuals, Technical Bulletins, Supply Manuals (types 7,8, and 9), Supply Bulletins, Lubrication Orders, and Modification Work Orders.

TM 11-2062

Test Sets I-142-B, and Telephone Test Set AN/PTM-6.

TM 11-5527

Multimeters TS-352/U, TS-352A/U, and TS-352B/U.

TM 38-750

Army Equipment Record Procedures.

APPENDIX B

BASIC ISSUE ITEMS

Section I. INTRODUCTION

B-1. General

This appendix comprises the list for Hand-set H-189/GR. Component items are not required for installation, operation, or operators maintenance.

units because of precious metal content, critical materials, high dollar value reusable casings or castings.

B-2. Explanation of Columns

An explanation of the columns in section I is given below.

a. Source, Maintenance, and Recoverability Codes, Column 1.

- (1) *Source code, column 1a.* The selection status and source for the listed item is noted here. The source code used is —

Code	Explanation
A-----	Applies to assemblies that are not procured or stocked as such but are made up of two or more units, each of which carry individual stock numbers and descriptions and are procured and stocked and can be assembled by units at indicated maintenance categories.

- (2) *Maintenance code, column 1b.* The lowest category of maintenance authorized to install the listed item is noted here. The maintenance code used is as follows:

Code	Explanation
0-----	---_ Organizational maintenance

- (3) *Recoverability code, column 1c.* The information in this column indicates whether unserviceable items should be returned for recovery or salvage. Recoverability codes and their explanations are as follows:

Note. When there is no code indicated in the recoverability column, the part will be considered expendable.

Code	Explanation
U-----	Applies to repair parts specifically selected for salvage by reclamation

b. Federal Stock Number, Column 2. The Federal stock number for the item is indicated in this column.

c. Description, Column 3. The Federal item name, a five-digit manufacturer's code, and part number are included in this column.

d. Unit of Issue, Column 4. The unit used as a basis of issue (e.g. ea, pr, ft, yd, etc) is noted in this column.

e. Quantity Incorporated in Unit Pack, Column 5. Not used.

f. Quantity Incorporated in Unit, Column 6. The total quantity of the item used in the equipment is given in this column.

g. Quantity Authorized, Column 7. The total quantity of an item required to be on hand and necessary for the operation and maintenance of the equipment is given in this column.

h. Illustration, Column 8.

- (1) *Figure number, column 8a.* The number of the illustration in which the item is shown is indicated in this column.
- (2) *Item or symbol number, column 8b.* The call out number used to reference the item in the illustration appears in this column.

B-3. Federal Supply Codes

This paragraph lists the Federal supply code with the associated manufacturer's name.

Code	Manufacturer
80063--	-----Army Electronics Command

SECTION II. BASIC ISSUE ITEMS LIST

(1)										(4)	(5)	(6)	(7)	(8)	
SOURCE CD §	MAINT. CD §	REC. CODE §	BASIC ISSUE ITEMS LIST							UNIT OF ISSUE	QTY INC IN UNIT PACK	QTY INC IN UNIT	QTY AUTH	ILLUSTRATIONS	
			(2) FEDERAL STOCK NUMBER	(3) DESCRIPTION										(A) FIGURE NUMBER	(B) ITEM OR SYMBOL NUMBER
				MODEL											
			1	2	3	4	5	6							
A	O	U	5965-069-8886						HANDSET H-189/CR: 80063; SM-C-544226	ea				1	HSI
			ORD THRU AGC						TECHNICAL MANUAL TM 11-5965-280-15	ea			1		
									NOTE: A quantity of 1 technical manual is packed with each 12 equipments. Where a valid need exists, additional copies may be requisitioned and kept on hand.						
									NOTE: No parts authorized user, operator, crewman.						
									NOTE: No accessories, tools or test equipment are to be issued with this equipment.						
									NOTE: No basic issue items are mounted in or on this equipment.						

APPENDIX C

MAINTENANCE ALLOCATION

Section I. INTRODUCTION

C-1. General

This appendix provides a summary of the maintenance operations covered in the equipment literature for Handset H-189/GR. It authorizes categories of maintenance for specific maintenance functions on repairable items and components and the tools and equipment required to perform each function. This appendix may be used as an aid in planning maintenance operations.

C-2. Explanation of Format for Maintenance Allocation Chart

a. Group Number. Group numbers correspond to the reference designation prefix assigned in accordance with ASA Y32.16, Electrical and Electronics Reference Designations. They indicate the relation of listed items to the next higher assembly.

b. Component Assembly Nomenclature. This column lists the item names of component units, assemblies, subassemblies, and modules on which maintenance is authorized.

c. Maintenance Function. This column indicates the maintenance category at which performance of the specific maintenance function is authorized. Authorization to perform a function at any category also includes authorization to perform that function at higher categories. The codes used represent the various maintenance categories as follows:

Code	Maintenance category
C --__ -_	Operator's/crew
O --- ___ - ..	Organizational maintenance
F -----	Direct support maintenance
H _ -_	General support maintenance
D . _ -__	Depot maintenance

d. Tools and Equipment. The numbers appearing in this column refer to specific tools and equipment which are identified by these numbers in section III.

e. Remarks. Self-explanatory.

C-3. Explanation of Format for Tool and Test Equipment Requirements

The columns in the tool and test equipment requirements chart are as follows:

a. Tools and Equipment. The numbers in this column coincide with the numbers used in the tools and equipment column of the MAC. The numbers indicate the applicable tool for the maintenance function.

b. Maintenance Category. The codes in this column indicate the maintenance category normally allocated the facility.

c. Nomenclature. This column lists tools, test and maintenance equipment required to perform the maintenance functions.

d. Federal Stock Number. This column lists the Federal stock number.

e. Tool Number. Not used.

SECTION II. MAINTENANCE ALLOCATION CHART

MAINTENANCE ALLOCATION CHART																	
GROUP NUMBER	COMPONENT ASSEMBLY NOMENCLATURE	MAINTENANCE FUNCTIONS										TOOLS AND EQUIPMENT	REMARKS				
		INSPECT	TEST	SERVICE	ADJUST	ALIGN	CALIBRATE	INSTALL	REPLACE	REPAIR	OVERHAUL			REBUILD			
	HANDSET H-189/GR	C															Item not to be maintained above direct support organizations. Inspect, clean exterior, tighten element covers
		O	O	O										1,2			Inspect, test and replace earphone and microphone elements and gaskets, moisture shields. Collect units for further repair.
		F	F	F										1,2,3			Test and replace all parts in addition to above, including push switches and cable assemblies. Make operational check for return to user.

APPENDIX C

MAINTENANCE ALLOCATION

Section I. INTRODUCTION

C-1. General

This appendix provides a summary of the maintenance operations covered in the equipment literature for Handset H-189/GR. It authorizes categories of maintenance for specific maintenance functions on repairable items and components and the tools and equipment required to perform each function. This appendix may be used as an aid in planning maintenance operations.

C-2. Explanation of Format for Maintenance Allocation Chart

a. Group Number. Group numbers correspond to the reference designation prefix assigned in accordance with ASA Y32.16, Electrical and Electronics Reference Designations. They indicate the relation of listed items to the next higher assembly.

b. Component Assembly Nomenclature. This column lists the item names of component units, assemblies, subassemblies, and modules on which maintenance is authorized.

c. Maintenance Function. This column indicates the maintenance category at which performance of the specific maintenance function is authorized. Authorization to perform a function at any category also includes authorization to perform that function at higher categories. The codes used represent the various maintenance categories as follows:

Code	Maintenance Category
C --.. ----	Operator's/crew
O .. ___ - .__	Organizational maintenance
F -----	Direct support maintenance
H .. -.- _ -__	General support maintenance
D ___ -__	Depot maintenance

d. Tools and Equipment. The numbers appearing in this column refer to specific tools and equipment which are identified by these numbers in section III.

e. Remarks. Self-explanatory.

C-3. Explanation of Format for Tool and Test Equipment Requirements

The columns in the tool and test equipment requirements chart are as follows:

a. Tools and Equipment. The numbers in this column coincide with the numbers used in the tools and equipment column of the MAC. The numbers indicate the applicable tool for the maintenance function.

b. Maintenance Category. The codes in this column indicate the maintenance category normally allocated the facility.

c. Nomenclature. This column lists tools, test and maintenance equipment required to perform the maintenance functions.

d. Federal Stock Number. This column lists the Federal stock number.

e. Tool Number. Not used.

SECTION II. MAINTENANCE ALLOCATION CHART

MAINTENANCE ALLOCATION CHART																	
GROUP NUMBER	COMPONENT ASSEMBLY NOMENCLATURE	MAINTENANCE FUNCTIONS										TOOLS AND EQUIPMENT	REMARKS				
		INSPECT	TEST	SERVICE	ADJUST	ALIGN	CALIBRATE	INSTALL	REPLACE	REPAIR	OVERHAUL			REBUILD			
	HANDSET H-189/GR	C															Item not to be maintained above direct support organizations. Inspect, clean exterior, tighten element covers
		O	O	O										1,2			Inspect, test and replace earphone and microphone elements and gaskets, moisture shields.
		F	F	F										1,2,3			Collect units for further repair. Test and replace all parts in addition to above, including push switches and cable assemblies. Make operational check for return to user.

SECTION III. TOOL AND TEST EQUIPMENT REQUIREMENTS

TOOL AND TEST EQUIPMENT REQUIREMENTS				
TOOLS AND EQUIPMENT	MAINTENANCE CATEGORY	NOMENCLATURE	FEDERAL STOCK NUMBER	TOOL NUMBER
		H-189/GR (continued)		
1	C	TOOL KIT, RADAR AND RADIO REPAIRMAN TK-87/U	5180-690-4552	
2	O,F	MULTIMETER TS-352()/U	6625-0242-5023	
3	F	TEST SET, TELEPHONE AN/PTM-6	6625-229-1048	

APPENDIX D

ORGANIZATIONAL, DS, GS, AND DEPOT REPAIR PARTS

Section I. INTRODUCTION

D-1. Scope

This appendix contains a list of repair parts required for the performance of organizational maintenance and a list covering the corresponding requirements for direct support for Handset H-189/GR.

Note. No special tools, test, and support equipment are required for H-189/GR.

D-2. General

This repair parts list is divided into four principal parts:

a. Prescribed Load Allowance List (PLA) Section II. The PLA is a consolidated listing of repair parts allocated for initial stockage at organizational maintenance level. This is a mandatory minimum stockage allowance.

b. Repair Parts for Organizational Maintenance, Section III. Repair parts authorized for organizational maintenance is included in this section.

c. Repair Parts for Direct Support, General Support, and Depot Maintenance, Section IV. This chart lists repair parts authorized for maintenance performance at direct support.

d. Federal Stock Number Cross-Reference Index, Section V. This is a cross-reference index of Federal stock numbers to illustrations by figure and item number.

D-3. Explanation of Columns

An explanation of the columns in sections II through IV is given below.

a. Source, Maintenance, and Recoverability Codes, Column 1, Sections III and IV.

- (1) *Source, code, column 1a.* The selection status and source for the listed item is noted here. Source codes and their explanations are as follows :

Code	Explanation
P-----	Applies to repair parts that are stocked in or supplied from the GSA/DSA, or Army supply system, and authorized for use at indicated maintenance categories.
A ___--	Applies to assemblies that are not procured or stocked as such but are made up of two or more units, each of which carry individual stock numbers and descriptions and are procured and stocked and can be assembled by units at indicated maintenance categories.
X1 ---- ..	Applies to repair parts which are not procured or stocked, the requirement for which will be supplied by the use of next higher assembly or component.
X2 _____	Applies to repair parts which are not stocked. The indicated maintenance category requiring such repair parts will attempt to obtain them through cannibalization if not obtainable through cannibalization, such repair parts will be requisitioned with supporting justification through normal supply channels.
(2)	<i>Maintenance code, column 1b.</i> The lowest category of maintenance authorized to install the listed item is noted here.

Code	Explanation
O --- _-	Organizational maintenance
F -----	Direct support maintenance

- (3) *Recoverability code, column 1c.* The information in this column indicates whether unserviceable items should be returned for recovery or salvage. Recoverability codes and their explanations are as follows:

Note. When there is no code indicated in the recoverability column, the part will be considered expendable.

Code	Explanation
U -----	Applies to repair parts specifically selected for salvage by reclamation

units because of precious metal content, critical materials, high dollar value reusable casings or castings.

b. Federal Stock Number, Column 1, Section II; Column 2 Sections III and IV. The Federal stock number for the item is indicated in this column.

c. Description, Column 2, Section II; Column 3, Sections III and IV. The sequence number, Federal item name, a five-digit manufacturer's code, an indenture code, and a part number are included in this column. The indenture codes indicate the end item, the assemblies, and the component parts. Identical codes are parts of the preceding higher code.

d. Unit of Issue, Column 4, Sections III and IV. The unit used as a basis of issue (e.g. ea, pr, ft, yd, etc) is noted in this column

e. Quantity Incorporated in Unit Pack, Column 5. Not used.

f. Quantity Incorporated in Unit, Column 6, Sections III and IV The quantity of repair parts in an assembly is given in this column.

g. Maintenance Allowance, Column 3, Section II; Column 7, Sections III and IV.

- (1) The allowance columns are divided into subcolumns. The total quantity of items authorized for the number of equipments supported is indicated in each subcolumn opposite the first appearance of each item. Items authorized for use as required but not for initial stockage are identified with an asterisk (*) in the allowance column.
- (2) The quantitative allowances for organizational level of maintenance represents one initial prescribed load for a 15-day period for the number of equipments supported. Units and organizations authorized additional prescribed loads will multiply the number of prescribed loads authorized by the quantity of repair parts reflected in the appropriate density column to obtain the total quantity of repair parts authorized.

(3) Subsequent changes to organizational allowances will be limited as follows: No change in the range of items is authorized. If additional items are considered necessary, recommendation should be forwarded to Commanding General, U.S. Army Electronics Command, ATTN: AMSEL-MR-NMP-C, Fort Monmouth, N. J., 07703, for exception or revision to the allowance list. Revisions to the range of items authorized will be made by the USA ECOM National Maintenance Point based upon engineering experience, demand data, of TAERS information.

(4) The quantitative allowances for DS/GS levels of maintenance represent initial stockage for a 30-day period for the number of equipments supported.

h. One-Year Allowances Per 100 Equipments/Contingency Planning Purposes, Column 8, Section IV. Opposite the first appearance of each item, the total quantity required for distribution and contingency planning purposes is indicated. The range of items indicates total quantities of all authorized items required to provide for adequate support of 100 equipments for 1 year.

i. Illustration, Column 8, Section III, Column 10, Section IV.

- (1) *Figure number, column 8a, and 10a.* The number of the illustration in which the item is shown is indicated in this column.
- (2) *Item or symbol number, column 8b, and 10b.* The callout number used to reference the item in the illustration is indicated in this column.

J. Depot Maintenance Allowance Per 100 Equipments, Column 9. Not used.

D-4. Stockage

No parts authorized for stockage at general support. When unrepairable at direct support this equipment will be salvaged. Depot overhaul is not authorized.

D-5. Location of Repair Parts

a. When the Federal stock number is unknown, follow the procedures given in (1) through (3) below.

- (1) In the pertinent publication, find the repair part illustration to which the repair part belongs.
- (2) Locate the applicable illustration and note the figure number and item number.
- (3) Use the repair parts list to find the repair part and the figure number and item number as noted on the illustration.

b. When the Federal stock number is known, follow the procedures given in (1) and (2) above.

- (1) Use the Index of Federal stock Numbers to figure and item numbers and locate the Federal stock number. The Federal stock numbers are listed in numerical sequence and are cross referenced to the figure number and item number.
- (2) Use the repair part listing to find the repair part and the figure and item numbers as noted in the index of Federal stock numbers.

D-6. Federal Supply Codes

This paragraph lists the Federal supply code and the associated manufacturer's name.

Code Number	Manufacturer's name
80063	Army Electronics Command

SECTION II. PRESCRIBED LOAD ALLOWANCE LIST

PRESCRIBED LOAD ALLOWANCE						
(1) FEDERAL STOCK NUMBER	(1) DESCRIPTION	(3) 15-DAY ORG. MAINT. ALLOWANCE				(4) QTY INC IN UN PK
		(A)	(B)	(C)	(D)	
		1 -5	6 - 2 0	2 1 - 5 0	5 1-10 0	
5330-905-6032	"O" RING: 80063; USAECOM dwg SM-B-436332	*	*	2	2	
5330-933-7072	PACKING, PREFORMED: 80063; USAECOM dwg SM-B-544229	*	*	*	2	
5330-933-7073	PACKING, PREFORMED: 80063; USAECOM dwg SM-B-544228	*	*	*	2	
5930-933-6815	SWITCH PUSH: 80063; USAECOM dwg SM-B-544238	*	*	*	2	
5975-933-7075	BOOT, DUST: 80063; USAECOM dwg SM-B-544237	*	*	2	2	

SECTION III. REPAIR PARTS FOR ORGANIZATIONAL MAINTENANCE

SOURCE CD (1)	MAINT. CD (2)	REC. CODE (3)	REPAIR PARTS FOR ORGANIZATIONAL MAINTENANCE						(4) UNIT OF ISSUE	(5) QTY INC IN UN PK	(6) QTY INC IN UNIT	(7) 15 DAY ORG. MAINT. ALW.				(8) ILLUSTRATIONS		
			(2) FEDERAL STOCK NUMBER	(3) DESCRIPTION								(A) FIGURE NUMBER	(B) ITEM OR SYMBOL NUMBER					
				MODEL														
			1	2	3	4	5	6			1-5	6-20	21-50	51-100				
A	O	U	5965-069-8886						A001	HANDSET H-189/GR: 80063; USAECOM dwg SM-C-544226 (This item is nonexpendable)	ea							
P	O		5975-933-7075						A002	BOOT, DUST: 80063; USAECOM dwg SM-B-544237	ea	1	*	*	2	2	3	MF1
P	O		5330-905-6032						A003B	"O" RING: 80063; USAECOM dwg SM-B-436332	ea	1	*	*	2	2	4	MF2
P	O		5930-933-6816						A004	COVER, ELECTRICAL SWITCH: 80063; USAECOM dwg SM-B-544234	ea	1	*	*	*	*	3	MF3
P	O		5965-933-6893						A005	COVER, RECEIVER-TRANSMITTER: 80063; USAECOM dwg SM-B-544236	ea	1	*	*	*	*	2	MF4
P	O		5965-933-6897						A006	EARPHONE ELEMENT: 80063; USAECOM dwg SM-C-544262	ea	1	*	*	*	*	2	HT1
P	O		5965-933-6896						A008	MICROPHONE, ELEMENT: 80063; USAECOM dwg SM-D-544246	ea	1	*	*	*	*	2	HK1
P	O		5965-933-7020						A009	MOUTHPIECE, MICROPHONE: 80063; USAECOM dwg SM-B-544235	ea	1	*	*	*	*	2	MP6
P	O		5330-933-7072						A010	PACKING, PREFORMED: 80063; USAECOM dwg SM-B-544229	ea	1	*	*	*	2	2	MF7
P	O		5330-933-7073						A011	PACKING, PREFORMED: 80063; USAECOM dwg SM-B-544228	ea	1	*	*	*	2	2	MF8
P	O		5302-933-7070						A012	SCREW, MACHINE: 80063; USAECOM dwg SM-B-544232	ea	2	*	*	*	*	3	H1
P	O		5965-933-6895						A013	SHIELD, EARPHONE: 80063; USAECOM dwg SM-B-544231	ea	1	*	*	*	*	2	E1
P	O		5965-933-6894						A014	SHIELD, MICROPHONE: 80063; USAECOM dwg SM-B-544277	ea	1	*	*	*	*	2	E2

SECTION IV. REPAIR PARTS, DEPOT SUPPORT, GENERAL SUPPORT AND DEPOT MAINTENANCE

SOURCE CD (3)	MAINT. CD (3)	REC. CODE (3)	REPAIR PARTS FOR DIRECT SUPPORT, GENERAL SUPPORT, AND DEPOT MAINTENANCE										UNIT OF ISSUE (4)	QTY INC IN UN PK (5)	QTY INC IN UNIT (6)	30 DAY MAINT. ALW. (7)						1 YR. ALW. PER 100 EQUIP. CNTGTY PL. (8)	DEPOT MAINT. ALW. PER 100 EQUIP. (9)	ILLUSTRATIONS (10)				
			FEDERAL STOCK NUMBER (2)	MODEL (3)					DESCRIPTION (3)	DS						GS			FIGURE NUMBER (A)	ITEM OR SYMBOL NUMBER (B)								
				1	2	3	4	5		IND CD (3)	1-20 (A)	21-50 (B)				51-100 (C)	1-20 (A)	21-50 (B)			51-100 (C)							
A	O	U	5965-069-8886								A	A001	HANDSET H-189/GR: 80063; USAECOM dwg SM-C-54422C (This item is nonexpendable)	ea														
P	O		5975-933-7075								B	A002	BOOT, DUST: 80063; USAECOM dwg SM-B-544237	ea	1	2	2	3	-	-	-	33						MP1
P	F		5995-933-7180								B	A003	CABLE ASSEMBLY, SPECIAL PURPOSE, ELECTRICAL: 80063; USAECOM dwg SM-C-544283	ea	1	*	2	2	-	-	-	12						W1
P	F		5935-892-9833								C	A003A	CONNECTOR U-229/U: 80063; USAECOM dwg SC-DL-444445	ea	1	*	*	2	-	-	-	8						P1
P	O		5330-905-6032								C	A003B	"O" RING: 80063; USAECOM dwg SM-B-436332	ea	1	*	2	2	-	-	-	19						MP2
P	O		5930-933-6816								B	A004	COVER, ELECTRICAL SWITCH: 80063; USAECOM dwg SM-B-544234	ea	1	*	*	*	-	-	-	4						MP3
P	O		5965-933-6893								B	A005	COVER, RECEIVER-TRANSMITTER: 80063; USAECOM dwg SM-B-544236	ea	1	*	*	2	-	-	-	8						MP4
P	O		5965-933-6897								B	A006	EARPHONE ELEMENT: 80063; USAECOM dwg SM-C-544262	ea	1	*	*	2	-	-	-	8						HT1
X1	F										B	A007	HANDLE, HANDSET: 80063; USAECOM dwg SM-B-544284	ea	1													MP5
P	O		5965-933-6896								B	A008	MICROPHONE, ELEMENT: 80063; USAECOM dwg SM-D-544246	ea	1	*	*	2	-	-	-	8						MK1

(1) REPAIR PARTS FOR DIRECT SUPPORT, GENERAL SUPPORT, AND DEPOT MAINTENANCE											(10) ILLUSTRATIONS												
SOURCE CD (A)	MAINT. CD (B)	REC. CODE (C)	(2) FEDERAL STOCK NUMBER	(3) MODEL						(3) DESCRIPTION	(4) UNIT OF ISSUE	(5) QTY INC IN UN PK	(6) QTY INC IN UNIT	(7) 30 DAY MAINT. ALW.						(8) 1 YR. ALW. PER 100 EQUIP. PL. CNTGTY	(9) DEPOT MAINT. ALW. PER 100 EQUIP.	(A) FIGURE NUMBER	(B) ITEM OR SYMBOL NUMBER
				IND CD										DS			GS						
				1	2	3	4	5	6					1-20	21-50	51-100	1-20	21-50	51-100				
P	O		5965-933-7020						B	A009 MOUTHPIECE, MICROPHONE: 80063; USAECOM dwg SM-B-544235	ea	1	*	*	2	-	-	-	8	2	MP6		
P	O		5330-933-7072						B	A010 PACKING, PREFORMED: 80063; USAECOM dwg SM-B-544229	ea	1	*	2	2	-	-	-	12	2	MP7		
P	O		5330-933-7073						B	A011 PACKING, PREFORMED: 80063; USAECOM dwg SM-B-544228	ea	1	*	2	2	-	-	-	12	2	MP8		
P	O		5305-933-7070						B	A012 SCREW, MACHINE: 80063; USAECOM dwg SM-B-544232	ea	2	*	*	*	-	-	-	5	3	H1		
X2	F								B	A012A SCREW MACHINE: 80063; USAECOM dwg SM-B-544231	ea	1								3	H2		
P	O		5965-933-6895						B	A013 SHIELD, LARPHONE: 80063; USAECOM dwg SM-B-544281	ea	1	*	*	2	-	-	-	8	2	E1		
P	O		5965-933-6894						B	A014 SHIELD, MICROPHONE: 80063; USAECOM dwg SM-B-544277	ea	1	*	*	2	-	-	-	8	2	E2		
P	F		5930-933-6815						B	A015 SWITCH PUSH: 80063; USAECOM dwg SM-B-544238	ea	1	*	2	2	-	-	-	12	3	S1		

SECTION V. FEDERAL STOCK NUMBER INDEX

INDEX - FEDERAL STOCK NUMBER CROSS REFERENCE TO FIGURE AND ITEM NUMBER OR REFERENCE SYMBOL					
STOCK NO.	FIGURE NO.	ITEM NO. REF. SYMBOL	STOCK NO.	FIGURE NO.	ITEM NO. REF. SYMBOL
5305-933-7070	3	H1			
5330-905-6032	4	MP2			
5330-933-7072	2	MP7			
5330-933-7073	2	MP8			
5930-933-6815	3	S1			
5930-933-6816	3	MP3			
5935-892-9833	1	P1			
5965-069-8886	1	HS1			
5965-933-6893	2	MP4			
5965-933-6894	2	E2			
5965-933-6895	2	E1			
5965-933-6896	2	MK1			
5965-933-6897	2	HT1			
5965-933-7020	2	MP6			
5975-933-7075	3	MP1			
5995-933-7180	2	W1			

By Order of the Secretary of the Army:

HAROLD K. JOHNSON,
*General, United States Army,
Chief of Staff.*

Official:

KENNETH G. WICKHAM,
*Major General, United States Army,
The Adjutant General.*

Distribution:

Active Army:

USASA (2)
CNGB (1)
CC-E (7)
Dir of Trans (1)
CofEngrs (1)
TSG (1)
CofSptS (1)
USACDCEA (1)
USACDCCBRA (1)
USACDCCEA (1)
USACDCOA (1)
USACDCQMA (1)
USACDCTA (1)
USACDCADA (1)
USACDCARMA (1)
USACDCAVNA (1)
USACDCARTYA (1)
USACDCSWA (1)
USACDCCEA, Ft Huachuca (1)
USAARENBD (2)
USARADB (5)
USAAVNTBD (5)
USAMC (5)
USCONARC (5)
ARADCOM (5)
ARADCOM Rgn (2)
OS Maj Comd (4)
LOGCOMD (2)
USAMICOM (4)
USASTRATCOM (4)
USAESC (70)
USACDCEC (10)
MDW (1)
Armies (2) except
 Seventh (5)
 EUSA (5)
Corps (2)
USAC (3)
Div (2)
Bde (2)
Regt/Gp/bat gp (2)
Bn (2)
Co/Btry (2)

USMA (5)
Svc College (2)
USASECS (60)
USAADS (2)
USAAMS (2)
USAARMS (5)
USAIS (2)
USAES (2)
USACSS (5)
MFSS (5)
USAMPS (5)
WRAMC (1)
Army Pic Cen (2)
Instl (2) except
 Ft Hancock (4)
 Ft Gordon (10)
 Ft Huachuca (10)
 Ft Carson (25)
 Ft Knox (12)
 Ft Devens (5)
 Ft Belvoir (5)
 Ft Lee (5)
Gen Dep (2)
Sig Sec, Gen Dep (5)
Sig Dep (12)
Army Dep (2) except
LBAD (14)
 SAAD (30)
 TOAD (14)
 LEAD (7)
 NAAD (5)
 SVAD (5)
 ATAD (10)
WSMR (5)
Sig Fld Maint Shops (2)
AMS (1)
USACCREL (2)
USAERDAA (2)
USAERDAW (13)
Frankford Arsenal (10)
Edgewood Arsenal (10)
Redstone Arsenal (10)

NG: State AG (3) ; units — same as Active Army except allowance is one copy to each unit.

USAR: None.

For explanation of abbreviations used, see AR 320-50.

